

**IRS-P6
LGSOWG (Super Structure)
DIGITAL DATA PRODUCTS FORMAT**

MAY, 2003

**DPSD/SIPG/SIIPA
Space Applications Centre, ISRO, Ahmedabad, INDIA.**

TABLE OF CONTENTS

1.0 INTRODUCTION.....	5
2.0 SUPER STRUCTURED DIGITAL DATA FORMAT	6
2.1 FILE ORGANIZATION.....	6
2.1.1 LOGICAL VOLUME.....	6
2.1.2 VOLUME DIRECTORY FILE.....	6
2.1.3 LEADER FILE.....	6
2.1.4 IMAGE FILE.....	6
2.1.5 TRAILER FILE.....	6
2.1.6 NULL VOLUME DIRECTORY FILE.....	6
2.2 FILES AND RECORDS IN IRS-1C/1D/P3/P6/DAT.....	7
2.3 FILE STRUCTURE/NOMENCLATURE.....	8
2.3.1 DIGITAL DATA FILE STRUCTURE.....	8
2.3.2 CDROM Products Naming Conventions.....	9
2.3.2 DISK Products Naming Conventions.....	10
2.4 RECORD STRUCTURE	11
2.4.1 VOLUME DIRECTORY.....	11
2.4.2 FILE DESCRIPTOR RECORD.....	16
2.4.3 LEADER FILE.....	18
2.4.4 IMAGE DATA FILE.....	41
2.4.5 TRAILER FILE.....	45
2.4.6 NULL FILE.....	46
APPENDIX – 1A: CLARIFICATION OF EXISTING FORMAT	52
APPENDIX – 1B: USGS PROJECTION PARAMETERS.....	53
APPENDIX - 1C : EARTH ELLIPSOIDS.....	56
APPENDIX - 1D : ELLIPSOID AND DATUM MNEMONICS	57
APPENDIX - II: SUPER STRUCTURE FORMAT LAYOUT	58

1.0 INTRODUCTION

IRS-1C/1D/P3/P6 Data products system generates digital video data in DATs, CD-ROM and DISK on the basis of user requests. Hence forth these products will be referred to as Digital Product in general.

Digital products are supplied in four formats such as a) **LGSOWG**(Landsat Ground Station Operators Working Group) or **Super Structure Format** , b) **GeoTIFF**, c) **Fast Format** and d) **HDF**. This document gives details of LGSOWG Format Only. Video data will be provided in BIL or BSQ formats.

Whereas in super structure format apart from the video data each digital product contains scene identification, location information, sensor, platform and processing related information.

The clarification related to various records of **LGSOWG** format is given in **APPENDIX-1A**. Map projection parameters are given in **APPENDIX-1B**.

The superstructure layout in BIL and BSQ are shown in Figure-1 and **APPENDIX-II**.

Standard conventions used in the document is given in the **Table number 1.0**.

TABLE 1.0

Explanation for the notations used to describe the data type

Notation	Explanation
B	: Field coded in Binary
A	: Alphanumeric in ASCII
N	: Numeric in ASCII
In	: Integer numeric string with Length equal to n bytes.
Fw.d	: Floating point numeric string with length w, with d decimal digits.

NOTES:

- 1) Alpha-numeric information is left justified.
- 2) Numeric information is right justified.

2.0 SUPER STRUCTURED DIGITAL DATA FORMAT

2.1 FILE ORGANIZATION

The LGSOWG format contains basically five file as described below.

2.1.1 LOGICAL VOLUME

A logical volume is a logical collection of one or more files recorded consecutively.

All logical volumes have a volume directory as the first file and null volume directory as the last file. When a logical volume is split between physical volumes the volume directory is repeated at the start of the next physical tape with some updated information.

2.1.2 VOLUME DIRECTORY FILE

The volume directory file is the first file of every logical volume. It is composed of volume descriptor record, a number of file pointer records and a text record.

The volume descriptor record identifies the logical volume and the number of files it contains. There is a file pointer record for each type of file in the logical volume, which indicates each file's class, format and attributes.

2.1.3 LEADER FILE

The leader file is composed of a file descriptor record and three types of data records. The record types are header, ancillary and annotation. Header contains information related to mission; sensor and processing parameters. Ancillary records contain information related to ephemeris, attitude and Ground Control Points (GCPs) for image correction.

2.1.4 IMAGE FILE

Image file consists of file descriptor record and image data records. Image data record contain the video data in Band Interleaved by Line (BIL) format or Band Sequential Format (BSQ), and in addition, it also contains prefix and suffix information.

2.1.5 TRAILER FILE

The trailer file follows the image data file. This is composed of a file descriptor record and one trailer record for each band.

2.1.6 NULL VOLUME DIRECTORY FILE

The file, which ends a logical volume, is the null volume directory file. The file is referred as 'null' because it defines a non-existent (empty) logical volume. This file contains a volume descriptor record.

2.2 FILES AND RECORDS IN IRS-1C/1D/P3/P6/DAT

File Seq. No.	Record Type and length	Description of file contents
File 0	Variable no of Records each of 360 bytes.	Volume Directory file (Volume descriptor, File Pointers and text record).
File 1	* Variable no of Records each of 6120 bytes	Leader file (Descriptor, Header, ancillary, Calibration, histogram, map projection, GCP, annotation, Boundary, and Boundary annotation Record. CLASS LEAD
File2	* VariableNo.of records * Variable record length	Image Data file CLASS IMGY
File 3	Variable no of Records each of 360 bytes	Trailer file (Description and trailer records) CLASS TRAI
NULL	One Record of 360 bytes	Null file (End of logical volume will be overwritten to add another logical volume.)

* Number. of records and record length will vary as per the product type or number. of bands or sensor.

2.3 FILE STRUCTURE/NOMENCLATURE

2.3.1 DIGITAL DATA FILE STRUCTURE

Volume Directory	<ul style="list-style-type: none"> i) Volume Descriptor ii) File Pointer for file-1 iii) File Pointer for file-2 iv) File pointer for file-3 v) Text Record 	Volume Directory file	<p>Identification of logical</p> <p>Volume and file pointer record corresponding to each file of logical volume. Specific file format record length, number of records etc</p> <p>The text record gives information about physical tape, environment in which the tape has been created.</p>
1.	<ul style="list-style-type: none"> i) Leader file Descriptor ii) Header Record iii) Ancillary Records iv) Annotation Record v) Boundary Records and Boundary annotation record 	Leader file (LEAD)	<p>Gives the mode of reading file and contains key data field location.</p> <p>Information related to mission, sensor, processing parameters.</p> <p>Contains information about ephemeris, attitude, calibration histogram, map projection and GCP's</p> <p>Contains information about annotation and tick marks.</p> <p>These records are dummy.</p>
2.	<ul style="list-style-type: none"> i) Image file descriptor ii) Image data Records 	Image data file (IMGY)	<p>Gives the mode of reading the file and contains key data field locations.</p> <p>Contains RAW/PROCESSED/RADIOMETRIC Corrected Data</p>
3.	<ul style="list-style-type: none"> i) Trailer file descriptor ii) Trailer records 	Trailer file TRAI	<p>Gives the mode of reading the file and contains key data field locations.</p> <p>These contain information about cloud coverage and parity errors.</p>
NULL VOLUME	i) NULL VOLUME Descriptor Record	Null Volume file	Last file of the logical volume. The purpose of this is to mark the end of logical volume.

2.3.2 CDROM Products Naming Conventions

In case of CDROM product a typical CD will contain following files.

- a) **CDINFO** – a file describing the Satellite name, Product Code, Path, Row, Date Of Pass, Sensor, Volume number etc. It is basically gives the information about the contents of CD. Typical content of a CDINFO file for P6 will look like this.

PRODUCT 1 :

Product number	: JobId	(Twelve Character)
Satellite ID	: P6	(Two Character)
Sensor	: L-3	(Three Character)
Path-Row	: 096-055	(Seven Character)
Date& time of Acquisition	: 28-MAR-02 05:50:39	Eighteen Character)
Product Code	: STPCD027J	(Nine Character)
Orbit Number	: 1	
Image Layout	:BSQ	
Number of Bands	: 4	
Bands Present in Product	: 2 3 4 5	
Bands in this volume	: 2 3 4 5	
File Header	: 540	
Line Header (Prefix Bytes)	: 32	
Line Trailer (Suffix Bytes)	: 0	
Scan Lines	: 5545	
Pixels	: 5918	
Bytes Per Pixel	: 1	
Image Record Length (Bytes)	: 5950	
No of Volume	: 1/1	(3 Character-CurVol/NoOfPhyVol)

- b) **PRODUCT1**- a directory containing following files.

- 1) **VOLUME.SensorCode/DAT** – the Volume Directory File.
- 2) **LEADER.SensorCode/DAT** - the Leader File.
- 3) **IMAGERYb.SensorCode/DAT**- the Imagery File.
- 4) **TRAILER.SensorCode/DAT** – the Trailer File.
- 5) **NULL.SensorCode/DAT** - the Null Volume File.

Where b=Band number. In case of PAN ‘b’ will not be present. and SensorCode=Three Character Sensor Code , shown in **Table 2.3.1** below.

Sr. No.	Sensor Name	Sensor Code (Three Character)	Possible values for ‘b’ used in Imagery File.
1	LISS-3	L-3(for 1C/1D/P6)	2,3,4,5
2	LISS-4	L-4	2,3,4
3	AWiFS	AWF	2,3,4,5
4	PAN	PAN (for 1C/1D)	NIL
5	WiFS	WIF (for 1C/1D)	3,4

Table 2.3.1 Sensor Code and Band Combination

NOTE : The default file name extension is *.SensorCode*. The alternative extension available is **.DAT**. The extension based on sensor code and DAT is configurable as per user requirement.

Multi Volume CD Products

In case of multi volume CD-ROM products the file structure will be similar to single volume except the entry against *No of volume* field in CDINFO file. The Number of volume field will have entry like

CurrentPhysicalVolume/TotalNoOfPhysicalVolume.

e.g. For a two volume CD Product CDINFO file will have following entries entry

No of Volume : 1/2 (CDINFO of volume1)
No of Volume : 2/2 (CDINFO of volume2)

More than one Products in a single CD

In case of more than one products to be written into a single CD there will be a separate directory entry for each product to distinguish each. The name of the directory will be 12 character Job id. The contents within individual directories will be exactly similar to single product CD.

e.g. consider two products with 12 character JobId1 and JobId2. The CDROM will contain two directories named JobId1 and JobId2. The underlying contents of these directories will be exactly similar to single product in single CD.

NOTE : *The directory structure for CDROM products will be same for all formats (LGSOWG, Fast Format, GeoTIFF, HDF). CDINFO file contents will also be similar for all formats. Only the contents of the PRODUCT1 directory will vary from format to format. The structure for multi volume CD and single CD containing multiple products also will be same for all CDROM products irrespective of formats.*

2.3.2 DISK Products Naming Conventions

The disk products will be generated on the disk in specified directory, configured by DISK_FILE_PATH in DPS Scheduler setup. Following files will be generated in disk file path.

JobId.vol – the Volume Directory File.
JobId.led - the Leader File
JobId/JobId_bn.img- the Imagery File.
JobId.trl – the Trailer file
JobId.nul- the Null Volume File.

Where JobId= 12 character uniquerequest or Job Identification code.

bn = Band Number . Not relevant for PAN. ***So in case of PAN JobId.img will be created.***

2.4 RECORD STRUCTURE

2.4.1 VOLUME DIRECTORY

- i) Volume Descriptor Record
- ii) File Pointer Records (number of records will depend on the number of files in the product).
- iii) Text Record

The table in the next page describes the Volume Directory in detail.

TABLE 2.4.1.1**VOLUME DESCRIPTOR RECORD : (DEFINITIONS /CONTENTS)
(360 Bytes)**

FIELD NO.	BYTE NO	TYPE	DESCRIPTION
1	1-4	B	The record number of this record within the file (1)
2	5-8	B	Record type and subtype octal codes ("300 300 022 022")
3	9-12	B	Length of this record (360)
4	13-14	A	ASCII/EBCDIC Flag (Ab) - A2
5	15-16	A	Product Endian e.g. MM (Motorola-Big Endian) or II (Intel-Little Endian)
6	17-28	A	Super structure format control document number - A12
7	29-30	N	Super structure control document revision number - I2
8	31-32	A	Super structure control document revision letter - A2
9	33-44	A	Software release number A12 (ex. IRS P6DPSV1R2)
10	45-60	A	Tape ID for physical volume containing this volume descriptor - A16 (D 010008600 401-01) UXXXXXXXXXXXXX-NN (U = C/Z/D)Z=DISK U = Output Media Symbol; C: CDROM,, D: DAT, U: Other Media XXXXXXXXXXXXX = Unique identification of the product NN = Current physical volume in volume set
11	61-76	A	Logical volume ID - A16 (P6-MS-BSQ-L-3-01) SS-NN-MMM-LLL-KK SS = Satellite Id. (e.g. 1C/1D/P6) NN = Mode of data acquisition (PA for panchromatic, MS for multi spectral mode) MMM= Interleaving indicator (BIL or BSQ) LLL=Sensor Identification (L-3, WIF, PAN,L4M,L4X,AWF) KK = Present logical volume no in volume set
12	77-92	A	Volume set ID - A16 (P6-MS-BSQ-L-3-01) SS-NN-MMM-LLL-KK KK = Total no. of logical volume in volume set rest defined in field 11.
13	93-94	N	Number of physical volume in the Volume set - I2
14	95-96	N	Physical volume number, start of logical volume - I2
15	97-98	N	Physical volume number, end of logical volume - I2
16	99-100	N	Physical volume number containing this volume descriptor - I2
17	101-104	N	First file number reference in this physical volume - I4
18	105-108	N	Logical volume number within volume set - I4
19	109-112	N	Logical volume number within this physical volume - I4
20	113-120	A	Logical volume creation date (YYYYMMDD) - A8

21	121-128	A	Logical volume creation time (HHMMSS)- A8
22	129-140	A	Logical volume generating country - A12 (INDIA)
23	141-148	A	Logical volume generating agency - A8
24	149-160	A	Logical volume creation facility - A12
25	161-164	N*	Number of pointer records in volume directory (bbbN) - I4
26	165-168	N*	Total Number of records in volume directory (bbbN) - I4
27	169-360	-	Spares

* These fields will have different contents for different products.

TABLE 2.4.1.2**FILE POINTER RECORDS : DEFINITIONS/CONTENTS (360 BYTES)**

FIELD NO.	BYTE NO.	TYPE	DESCRIPTION
1	1-4	B	The record number of this record within the volume directory file (2,3 or 4)
2	5-8	B	Record type and subtype octal codes ("333 300 022 022")
3	9-12	B	Length of this record (360)
4	13-14	A	ASCII/EBCDIC flag (Ab) - A2
5	15-16	-	Spares
6	17-20	N	Reference file number (bbb1, bbb2, or bbb3) - I4
7	21-36	A	Referenced file name - A16
8	37-64	A	Referenced file class (LEADERbFILEb,IMAGERYbFILE or TRAILERbFILE : Plus 16 blanks) - A28
9	65-68	A	Reference file class code (LEAD, IMGY, TRAI) - A4
10	69-96	A	Reference file data type MIXED BINARY AND ASCII (MBAA) or BINARY ONLY (BINO)- A28
11	97-100	A	Referenced file data type code (MBAA or BINO) - A4
12	101-108	N	Number of records in referenced file - I8
13	109-116	N	Referenced file first record length - I8
14	117-124	N	Referenced file maximum record length -I8
15	125-136	A	Referenced file record length type - A12
16	137-140	A	Referenced file record length type code - A4
17	141-142	A	Referenced file physical volume, start of file - I2
18	143-144	N	Referenced file physical volume, end of file - I2
19	145-152	N	Referenced file, 1st record number in this physical volume - I8
20	153-160	N	Referenced file, number of records in this physical volume - I8
21	161-360	-	Spares

TABLE - 2.4.1.3

TEXT RECORD: DEFINITIONS/CONTENTS (360 Bytes)

FIELD NO.	BYTE NO.	TYPE	DESCRIPTION
1	1-4	B	Record Sequence Number of this record
2	5-8	B	Record type and subtype octal codes ("022 077 022 022")
3	9-12	B	Length of this record (360)
4	13-14	A	ASCII/EBCDIC Flag (Ab) - A2
5	15-16	A	Continuation Flag (NO) - A2
6	17-32	A	Product type (RAW, STEREO, PATH BASED, SPECIAL, GEOCODED, GEOR EFERENCED, RADIOMETRIC, ORTHO, PRECISION) - A16
7	33-48	A	Date of product creation (DD-MM-YY)-A16
8	49-64	A	Time of product creation (HH:MM:SS)-A16
9	65-80	A	Physical tape ID (16 character long string as `name' to physical tape)- A16(+)
10	81-112	A	Scene ID - A32 (*)
11	113-172	A	State & District name - A60
12	173-180	A	Map Sheet Number - A8
13	181-199	A	Spares
14	200-208	A	Product Code - A9 (ST000017I)
15	209-360	A	Spares

(*) Scene ID coded as follows : (06-JAN-02 05:50:52 L-3 ST00B 2345F)

1. 1:8 DD-MMM-YY (Date of Pass)
2. 9:10 Blank
3. 11:18 HH:MM:SS (Time of acquisition in UT)
4. 19:21 Sensor ID (L-3,P-(A,B,C,D), WIF,AWF,L4M,L4X)
5. 22:22 Sub scene ID (0-9) ,A,B,C,D and F (for full scene)
6. 23:24 Product type code (e.g. ST/TR/QU/GR/G3/J3/G4/J4/J5/SR)
7. 25:26 % shift along track
8. 27:27 'B'
9. 28:31 Band numbers
10. 32:32 Flag for full = 'F' or Quad='Q'

(+) Refer **table No.2.4.1.1** (field No.10)

Note: YY in the Date of Pass field location No. 7 & 8 is to be interpreted as follows..

- 99 → 1999
- 00 → 2000
- 01 → 2001

2.4.2 FILE DESCRIPTOR RECORD

1. Fixed part of the file Descriptor record

TABLE 2.4.2.1
FIXED PART OF THE FILE DESCRIPTION RECORDS
DEFINITIONS/CONTENTS (180 Bytes)

FIELD NO.	BYTE NO.	TYPE	DESCRIPTION
1	1-4	B	Record Number of this record within the file (1)
2	5-8	B	Record type and subtype octal codes ("077 300 022 022")
3	9-12	B	Length of this record
4	13-14	A	ASCII/EBCDIC Flag - A2
5	15-16	-	Spares
6	17-28	A	Superstructure format control document number - A12
7	29-30	N	Superstructure control document revision number - I2
8	31-32	N	Superstructure control document revision letter - A2
9	33-44	A	Software release number - A12
10	45-48	N	Sequence number of this file within the logical volume (excluding volume directory) (1 or 2 or 3. etc) - I4
11	49-64	A	File name (unique identification of the present file)
12	65-68	A	Record sequence and location type flag (Indicates whether other records in the file have sequence number or not)
13	69-76	N	Location of the start of the sequence number field (bbbbbbb4)-I8
14	77-80	N	Length in bytes of the record sequence number field (bbb4) - I4
15	81-84	A	Record code and location type flag (indicates whether other records in the file have a record type code or not and their location is fixed or not)
16	85-92	N	Location of the start of the record type code field (bbbbbbb5) - I8
17	93-96	N	Length in bytes of the record type code field (bbb4) - I4
18	97-100	A	Record length and location type flag (Indicates whether other records in this file have its record length recorded within the record or not and location is fixed or not: - FLGT (Fixed in IRS- format) - A4
19.	101-108	N	Location of the start of the record length field (bbbbbbb9) - I8
20.	109-112	N	Length in bytes of the record length field (bbb4) - I4
21.	113	A	Flag indicating that the data interpretation information is included with the file descriptor record - A1

22.	114	A	Flag indicating that the data interpretation information is included within the file in records other than the files descriptor record - A1
23.	115	A	Flag indicating that the data display information is included with the file description record - A1
24.	116	A	Flag indicating that the data display information is included within the file in records other than the file descriptor record - A1
25.	117-180	-	Spares

2.4.3 LEADER FILE

1. File Descriptor Record
2. Header Record
3. Ephemeris/Attitude Record
- & 4. Calibration Records
5. Map Projection Record
6. Histogram Records
7. GCPs Record
8. Annotation Record
- * 9. Line & Pixel look up table
- \$ 10. Attitude Rate Record
- \$ 11. Boundary Records
- \$ 12. Boundary annotation Record
- \$ These records are dummy and not valid for P6.

& Valid for Raw or Radiometrically corrected products. Other products will contain dummy record.

* Valid for Basic Stereo products only. Other products will contain dummy record.

TABLE 2.4.3.1**LEADER FILE DESCRIPTOR RECORD :**
DEFINITIONS/CONTENTS (6120 Bytes)

FIELD NO	BYTE NO	TYPE	DESCRIPTION
1	1-180	-	See 2.4.2.1 (Fixed part of the file descriptor)
2	181-186	N	Number of header records (bbbbbb1) - I6
3	187-192	N	Header record length (bb6120) – I6
4	193-198	N	Number of ancillary `Ephemeris/attitudes' record - I6
5	199-204	N	Length of this record - I6
6	205-210	N	Number of `Calibration'records - I6
7	211-216	N	Length of these records - I6
8	217-222	N	Number of ancillary `Histogram record'-I6
9	223-228	N	Length of these records - I6
10	229-234	N	Number of `MAP PROJECTION' records -I6
11	235-240	N	Length of these records - I6
12	241-246	N	Number of `GCP'records - I6
13	247-252	N	Length of these records - I6
14	253-258	N	Number of annotation Records I6
15	259-264	N	Length of these records - I6
16	265-270	N	Line & pixel lookup table records- I6
17	271-276	N	Length of these records I6
18	277-282	N	Number of Attitude Rate Records - I6
19	283-288	N	Length of these records - I6
20	289-294	N	Number of boundary records -I6
21	295-300	N	Length of these records -I6
22	301-306	N	Number of boundary annotation records -I6
23	307-312	N	Length of these records -I6 The location of the below mentioned fields is given in 16 bytes, coded as follows 6 bytes - the record number of the record containing the field 6 bytes - byte number of the 1st byte of this field 3 bytes - length of these fields in bytes 1 bytes - Code for the type of data in the field (A=alphanumeric, B=binary, N=numeric)
24	313-324		Spares
25	325-340	A	Scene identification field locator - A16
26	341-356	A	Mission identification field locator -A16
27	357-372	A	Sensor identification field locator - A16
28	373-388	A	Exposure date & time locator - A16
29	389-404	A	Geographic field reference locator - A16
30	405-420	A	Image processing performed field locator - A16
31	421-436	A	Imagery format indicator locator (Interleaving) - A16
32	437-452	A	Band indicator locator – A16
33	453-6120	-	Spares

TABLE 2.4.3.2**HEADER RECORD : DEFINITION/CONTENTS - (6120 Bytes)**
(For IRS-P6)

FIELD NO.	BYTE NO.	TYPE	DESCRIPTION
1	1-4	B	Record Number of this record within file
2	5-8	B	Record type and subtype octal codes ("022 022 022 022")
3	9-12	B	Length of this record (6120)
4	13-16	N	Header Record sequence number -I4
5	17-20	-	Blanks
6	21-28	N	Path Number (bbbbPPP)-I8
7	29-36	N	Row Number (bbbbRRR)-I8
8	37-68	A	Scene Identification-A32 +
9	69-100		Spares
10	101-116	N	Scene Centre Geographic location (lat) (Deg.) - F16.7
11	117-132	N	Scene Centre Geographic location (long) (Deg.) F16.7
12	133-140	N	Scene centre location within image (line no.) -I8
13	141-148	N	Scene centre location within image (pixel no) - I8
14	149-164	N	Left top corner geographic location of scene (lat) (Deg.) - F16.7
15	165-180	N	Left top corner geographic location of scene (long) (Deg.) - F16.7
16	181-188	N	Left Top corner location in scene (line no.) - I8
17	189-196	N	Left top corner location in scene (pixel no.) - I8
18	197-212	N	Right top corner geographic location (lat)-F16.7
19	213-228	N	Right Top corner geographic location (long) – F16.7
20	229-236	N	Right top corner location in scene (line no) - I8
21	237-244	N	Right top corner location in scene (pixel no)-I8
22	245-260	N	Left bottom corner geographic location of scene (lat.)-F16.7
23	261-276	N	Left bottom corner geographic location of scene (long)- F16.7
24	277-284	N	Left bottom corner location in scene (line no)-I8
25	285-292	N	Left bottom corner location in scene (pixel no)-I8
26	293-308	N	Right bottom corner geographic location of scene (lat)-F16.7
27	309-324	N	Right bottom corner geographic location of scene (long)-F16.7
28	325-332	N	Right Bottom corner location in scene (line no) -I8
29	333-340	N	Right Bottom corner location in scene (pixel no) -I8
30	341-348	N	Input nominal scene data (pixels)-I8
31	349-356	N	Input nominal scene data (lines)-I8
32	357-364	N	Input nominal pixel size at nadir - (meters) - F8.3
33	365-372	N	Input nominal line spacing at nadir - (meters) – F8.3

34	373-388	N	Input viewing angle (Deg.) - F16.7	
35	389-396	N	Input nominal pixels for SWIR band-I8	
36	397-404	N	Input nominal scans for SWIR band-I8	
37	405-412	N	Input nominal pixel size for SWIR band F8.3	
38	413-420	N	Input nominal line spacing for SWIRband I8	
39	421-436	N	Nominal orbit inclination (Deg.) - F16.7	
40	437-452	N	Nominal altitude (meters) - F16.7	
41	453-468	N	Longitude of ascending node, F16.7	
41A	469-470	N	Endian Flag (0:for Big Endian, 1: Little Endian)	
41B	471-472	N	Shift percentage(0 -99) I2, for shift along track products, I2	
41C	473-474	N	Quadrant Number (Valid for Quadrant products only), I2	
41D	475-482	A	CCD1CorrFlag	
41E	483-501	-	Spares	
42	502-517	N	Satellite heading angle (Deg.) - F16.7	
43	518-525	N	Orbit Number, I8	
44	526-541	N	Instantaneous Cross track FOV in radians -F16.7	
45	542-573	-	Spares	
46	574-589	N	Sun angle (Azimuth) (Deg.) – F16.7	
47	590-605	N	Sun angle (elevation) (Deg.) F16.7	
48	606-621	N	Predicated scene center latitude (deg.) F16.7	
49	622-637	N	Predicated scene centre longitude (deg.) F16.7	
50	638-653	N	Observed scene center latitude (deg.) F16.7	
51	654-669	N	Observed scene center longitude (deg.) F16.7	
#	52a	670-679	N	Roll BIAS F10.5
#	52b	680-689	N	Pitch BIAS F10.5
#	52c	690-699	N	Yaw BIAS F10.5
#	52d	700-703	A	Pass Type PLD- Payload Pass,SSD-SSR Day Pass(Solid State Recorder),SSN-SSR Night Pass
#	52e	704-797	-	Spares
<u>IMAGING PARAMETERS</u>				
53	798-829	A	Input scene start time (HH:MM:SS: mmm)	
54	830-845	A	Mission identification-A16	
55	846-877	A	Sensor identification – A32	
56	878-893	A	Spectral mode – A16	
57	894-913		Spares	
58	914-929	N	Day number within cycle-I16	
59	930-937	N	Payload tilt step number – I8	
60	938-945	N	Payload tilt per step in (Deg) – F8.3	
61	946-961	N	LISS-3 scene centre lat. Corresponding to PAN – F 16.7	
62	962-977	N	LISS-3 scene centre long. Corresponding to PAN – F 16.7	
63	978-985	N	LISS-3 Path no. Corresponding to PAN- I8	
64	986-993	N	LISS-3 Row no. Corresponding to PAN- I8	
65	994-1009	N	Integration Time for SWIR band – F 16.7	

66	1010-1025	N	Integration Time (in milli sec) – F 16.7
# 67a	1026-1061	A	Start time for LISS-4 “nb” A12
# 67b	1062-1076	N	Start pixel number for LISS-4 “nb” I5
# 67c	1077-1088	-	Spares
68	1089-1104	N	On board gain number “nb” I4
69	1105-1112	-	Spares
70	1113-1120	N	Number of spectral bands-I8
71	1121-1152	N	Lower and upper limit of wavelength range in nanometers range in nanometers 2”nb” F4.2 where nb = no. of bands in the sensor.
72	1153-1216	N	CCD temp for all the CCD arrays present in sensor “nb” F8.4 (in degree Celsius)
73	1217-1280	-	Minimum (LMIN) & Maximum (LMAX) radiance for number of bands present in the product 2”nb” F8.5 (mw/sq. cm / str / micromet)
Conversion formula for Digital Count to radiance is as follows. Lrad = (DN/MaxGray)*(Lmax – Lmin) + Lmin. Lrad : Radiance for a given DN value. DN : Digital Count MaxGray : IRS-1C/1D : 63 for PAN & 127 for WiFS & LISS-3 for Raw Products only. 255 for Corrected products. For IRS-P6 : 127 for LISS-4 and LISS-3, 1023 for AWiFS for raw products only. 255 for LISS-3&4, 1023 for AWiFs for corrected products Lmin/Lmax : Minimum/Maximum radiance value for a given band.			
IMAGE DATA PARAMETERS			
74	1281-1296	N	Number of image pixels per line-I16
75	1297-1312	N	Number of image data lines-I16
76	1313-1320	N	Processed pixel spacing F8.3
77	1321-1328	N	Processed line spacing F8.3
78	1329-1344	A	Interleaving indicator-A16
79	1345-1360	N	Spectral bands indicator – 4I4
80	1361-1368	N	Processed pixel spacing for SWIR band F8.3
81	1369-1376	N	Processed line spacing for SWIR band-F8.3
82	1377-1392	N	Number of Image pixels per line for SWIR band – I16
83	1393-1408	N	Number of Image data line for SWIRband – I16
84	1409-1440		Spares
85	1441-1456	A	Preprocessing level identification-A16 LEVEL-0 : for RAW Products LEVEL-1 : for RAD Products (Radiometric Correction only) LEVEL-2 : for Radiometric Correction + Systematic Geometric Correction LEVEL-3 : Precision Corrected
86	1457-1464	A	Radiometric calibration designator-A8 DONE : for Radiometrically corrected products

			NOT DONE : for RAW products.
87	1465-1472	A	Resampling designator –I8
88	1473-1632	-	Spares
89	1633-1648	N	Number of lines losses “nb”I4
90	1649-1664	N	Number of dead detectors “nb”I4
91	1665-1669	A	Multi Scene/Sensor flag (TRUE or FALSE) – A5
92	1670-1675	N	No. of Mosaicked or merged scenes I6
93	1676-1707	A	Second scene identification A32
94	1708-1713	A	Second scene satellite identification A6
95	1714-1721	N	Second scene input nominal resolution (meters) F8.3
96	1722-1737	N	Second scene sun elevation angle (deg.) – F16.7
97	1738-1753	N	Second scene sun azimuth angle (deg.) – F16.7
98	1754-1769	N	Observed scene centre latitude (deg.) – F16.7
99	1770-1785	N	Observed scene centre longitude (deg.) – F16.7
100	1786-1801	N	Second scene heading angle (deg.) – F16.7
101	1802-1817	N	Predicted second scene centre latitude (deg.) – F16.7
102	1818-1833	N	Predicted Second Scene Centre Longitude (deg.) – F16.7
103	1834-3097	N	Repetition of field no. 93,94,95,96,97,98,99,100,101,102 for remaining number of scenes. (8 times)
# 104	3098-3098	A	Source for orbit value flag– A1 0=Regular State Vec, 1=SANGAM processed Ground mode 2=SANGAM processed Onboard mode
# 105	3099-3099	A	Source for attitude value flag– A1 0=Ground Attitude Determination not possible 1=ADAGE determined Q’s(ES+GYRO) 2=ADJUST determined Q’s(defau)(STAR SEN) 3=AOCE determined Q’s
# 106	3100-3100	A	Yaw steering flag – A1 0=Yaw steering not done 1=Yaw steering done
# 107	3101-3124	N	Stagger Value “nb” F6.3, Odd and Even detector Stagger Factor(no of lines) for L4
# 108	3125-3125	A	ADIF regeneration flag 1 to 9 (counter for Regenerated ADIF), 0=for Original ADIF
# 109	3126-3137	N	Focal length for Band 2 (in mm) F12.7
# 110	3138-3149	N	Focal length for Band 3 (in mm) F12.7
# 111	3150-3161	N	Focal length for Band 4 (in mm) F12.7
# 112	3162-3173	N	Focal length for Band 5 (in mm) F12.7
# 113	3174-3189	N	BBR Coefficient for Band 2 for Scan F16.7(10 Vals)
# 114	3190-3333	N	Repetition of field no 113
# 115	3334-3349	N	BBR Coefficient for Band 2 for Pixel F16.7(10 Vals)
# 116	3350-3493	N	Repetition of field no 115
# 117	3494-3509	N	BBR Coefficient for Band 3 for Scan F16.7(10 Vals)
# 118	3510-3653	N	Repetition of field no 117
# 119	3654-3669	N	BBR Coefficient for Band 3 for Pixel F16.7(10 Vals)
# 120	3670-3813	N	Repetition of field no 119

# 121	3814-3829	N	BBR Coefficient for Band 4 for Scan F16.7(10 Vals)
# 122	3830-3973	N	Repetition of field no 121
# 123	3974-3989	N	BBR Coefficient for Band 4 for Pixel F16.7(10 Vals)
# 124	3990-4133	N	Repetition of field no 123
# 125	4134-4149	N	BBR Coefficient for Band 5 for Scan F16.7(10 Vals)
# 126	4150-4293	N	Repetition of field no 125
# 127	4294-4309	N	BBR Coefficient for Band 5 for Pixel F16.7(10 Vals)
# 128	4310-4453	N	Repetition of field no 127
# 129	4454-4465	N	MRC/PRC Angle for Roll/Pitch/Yaw F12.7(3 Vals) for AWiFS
# 130	4466-4489	N	Repetition of field no 129
# 131	4490-5304		Spares
# 132	5305-6120	A	For DPS Internal Use

“nb” stands for no. of bands/CCD arrays.

+ Refer **table 2.4.1.3** (Field No.10)

- Refer **table 2.4.1.3** (Field No.10)

- # New Fields in Header Record of LGSOWG for IRS-P6

NOTE : Field 88b to 88e will be repeated for maximum number of bands (for IRS-P6 it will be

TABLE 2.4.3.2**HEADER RECORD : DEFINITION/CONTENTS - (6120 Bytes)
(For IRS-1C/1D)**

FIELD NO.	BYTE NO.	TYPE	DESCRIPTION
1	1-4	B	Record Number of this record within file
2	5-8	B	Record type and subtype octal codes ("022 022 022 022")
3	9-12	B	Length of this record (6120)
4	13-16	N	Header Record sequence number -I4
5	17-20	-	Blanks
6	21-28	N	Path Number (bbbbPPP)-I8
7	29-36	N	Row Number (bbbbRRR)-I8
8	37-68	A	Scene Identification-A32 +
9	69-100		Spares
10	101-116	N	Scene Centre Geographic location (lat) (Deg.) - F16.7
11	117-132	N	Scene Centre Geographic location (long) (Deg.) F16.7
12	133-140	N	Scene centre location within image (line no.) -I8
13	141-148	N	Scene centre location within image (pixel no) - I8
14	149-164	N	Left top corner geographic location of scene (lat) (Deg.) - F16.7
15	165-180	N	Left top corner geographic location of scene (long) (Deg.) - F16.7
16	181-188	N	Left Top corner location in scene (line no.) - I8
17	189-196	N	Left top corner location in scene (pixel no.) - I8
18	197-212	N	Right top corner geographic location (lat)-F16.7
19	213-228	N	Right Top corner geographic location (long) - F16.7
20	229-236	N	Right top corner location in scene (line no) - I8
21	237-244	N	Right top corner location in scene (pixel no)-I8
22	245-260	N	Left bottom corner geographic location of scene (lat.)-F16.7
23	261-276	N	Left bottom corner geographic location of scene (long)- F16.7
24	277-284	N	left bottom corner location in scene (line no)-I8
25	285-292	N	Left bottom corner location in scene (pixel no)-I8
26	293-308	N	Right bottom corner geographic location of scene (lat)-F16.7
27	309-324	N	Right bottom corner geographic location of scene (long)-F16.7
28	325-332	N	Right Bottom corner location in scene (line no) -I8
29	333-340	N	Right Bottom corner location in scene (pixel no) -I8
30	341-348	N	Input nominal scene data (pixels)-I8
31	349-356	N	Input nominal scene data (lines)-I8

32	357-364	N	Input nominal pixel size at nadir - (meters) - F8.3
33	365-372	N	Input nominal line spacing at nadir - (meters) - F8.3
34	373-388	N	Input viewing angle (Deg.) - F16.7
35	389-396	N	Input nominal pixels for SWIR band-I8
36	397-404	N	Input nominal scans for SWIR band-I8
37	405-412	N	Input nominal pixel size for SWIR band F8.3
38	413-420	N	Input nominal line spacing for SWIRband I8
39	421-436	N	Nominal orbit inclination (Deg.) - F16.7
40	437-452	N	Nominal altitude (meters) - F16.7
41	453-468	N	Longitude of ascending node, F16.7
41A	469-470	N	Endian Flag (0:for Big Endian, 1: Little Endian)
41B	471-472	N	Shift percentage(0 -99) I2, for shift along track products, I2
41C	473-474	N	Quadrant Number (Valid for Quadrant products only), I2
41D	475-501	-	Spares
42	502-517	N	Satellite heading angle (Deg.) - F16.7
43	518-525	N	Orbit Number, I8
44	526-541	N	Instantaneous Cross track FOV in radians -F16.7
45	542-573	-	Spares
46	574-589	N	Sun angle (Azimuth) (Deg.) – F16.7
47	590-605	N	Sun angle (elevation) (Deg.) F16.7
48	606-621	N	Predicated scene center latitude (deg.) F16.7
49	622-637	N	Predicated scene centre longitude (deg.) F16.7
50	638-653	N	Observed scene center latitude (deg.) F16.7
51	654-669	N	Observed scene center longitude (deg.) F16.7
52	670-797	-	Spares
<u>IMAGING PARAMETERS</u>			
53	798-829	A	Input scene start time (HH:MM:SS: mmm)
54	830-845	A	Mission identification-A16
55	846-877	A	Sensor identification – A32
56	878-893	A	Spectral mode – A16
57	894-913		Spares
58	914-929	N	Day number within cycle-I16
59	930-937	N	Payload tilt step number - I8
60	938-945	N	Payload tilt per step in (Deg) - F8.3
61	946-961	N	LISS-3 scene centre lat. corresponding to PAN - F 16.7
62	962-977	N	LISS-3 scene centre long. corresponding to PAN - F 16.7
63	978-985	N	LISS-3 Path no. Corresponding to PAN- I8
64	986-993	N	LISS-3 Row no. Corresponding to PAN- I8
65	994-1009	N	Integration Time for SWIR band - F 16.7
66	1010-1025	N	Integration Time (in milli sec) - F 16.7
67	1026-1088		Spares
68	1089-1104	N	On board gain number "nb" I4
69	1105-1112		Spares

70	1113-1120	N	Number of spectral bands-I8
71	1121-1152	N	Lower and upper limit of wavelength range in nanometers range in nanometers 2^{nb} F4.2 where nb = no. of bands in the sensor.
72	1153-1216	N	CCD temp for all the CCD arrays present in sensor "nb" F8.4 (in degree Celsius)
73	1217-1280	-	Minimum (LMIN) & Maximum (LMAX) radiance for number of bands present in the product 2^{nb} F8.5 (mw/sq. cm / str / micromet)

Conversion formula for Digital Count to radiance is as follows.

$$\mathbf{Lrad} = (\mathbf{DN}/\mathbf{MaxGray}) * (\mathbf{Lmax} - \mathbf{Lmin}) + \mathbf{Lmin}.$$

Lrad : Radiance for a given DN value.

DN : Digital Count

MaxGray : **IRS-1C/1D** : 63 for PAN & 127 for WiFS & LISS-3 for Raw Products only.
255 for Corrected products.

Lmin/Lmax: Minimum/Maximum radiance value for a given band.

IMAGE DATA PARAMETERS

74	1281-1296	N	Number of image pixels per line-I16
75	1297-1312	N	Number of image data lines-I16
76	1313-1320	N	Processed pixel spacing F8.3
77	1321-1328	N	Processed line spacing F8.3
78	1329-1344	A	Interleaving indicator-A16
79	1345-1360	N	Spectral bands indicator - 4I4
80	1361-1368	N	Processed pixel spacing for SWIR band F8.3
81	1369-1376	N	Processed line spacing for SWIR band-F8.3
82	1377-1392	N	Number of Image pixels per line for SWIR band - I16
83	1393-1408	N	Number of Image data line for SWIRband - I16
84	1409-1440		Spares
85	1441-1456	A	Preprocessing level identification-A16 LEVEL-0 : for RAW Products LEVEL-1 : for RAD Products (Radiometric Correction only) LEVEL-2 : for Radiometric Correction + Systematic Geometric Correction LEVEL-3 : Precision Corrected
86	1457-1464	A	Radiometric calibration designator-A8 DONE : for Radiometrically corrected products NOT DONE : for RAW products.
87	1465-1472	A	Resampling designator -I8
88	1473-1632	-	Spares
89	1633-1648	N	Number of lines losses "nb" I4
90	1649-1664	N	Number of dead detectors "nb" I4
91	1665-1669	A	Multi Scene/Sensor flag (TRUE or FALSE) - A5
92	1670-1675	N	No. of Mosaicked or merged scenes I6

93	1676-1707	A	Second scene identification A32
94	1708-1713	A	Second scene satellite identification A6
95	1714-1721	N	Second scene input nominal resolution (meters) F8.3
96	1722-1737	N	Second scene sun elevation angle (deg.) - F16.7
97	1738-1753	N	Second scene sun azimuth angle (deg.) - F16.7
98	1754-1769	N	Observed scene centre latitude (deg.) - F16.7
99	1770-1785	N	Observed scene centre longitude (deg.) - F16.7
100	1786-1801	N	Second scene heading angle (deg.) - F16.7
101	1802-1817	N	Predicted second scene centre latitude (deg.) - F16.7
102	1818-1833	N	Predicted Second Scene Centre Longitude (deg.) - F16.7
103	1834-3097		Repetition of field no. 93,94,95,96,97,98,99,100,101,102 for remaining number of scenes.
104	3098-6120	-	Spares

"nb" stands for no. of bands/CCD arrays.

+ Refer **table 2.4.1.3** (Field No.10)

• Refer **table 2.4.1.3** (Field No.10)

TABLE 2.4.3.3
EPHEMERIES/ATTITUDE RECORDS
(DEFINITION/CONTENTS) (6120 Bytes)
(For IRS-P6)

FIELD NO	BYTE NUMBER	TYPE	DESCRIPTION
1	1-4	B	Record number of this record within file
2	5-8	B	Record type and subtype octal codes ("366 044 022 022")
3	9-12	B	Length of this record (6120)
4	13-16	N	Record sequence number in Ephemeris and attitude records – I4
5	17-20	N	Number of Ephemeris/Attitude/Q's values in this record – I4 (Maximum 20 values will be present)
6	21-32	N	Satellite position_X- F12.4 (kms)
# 7a.	33-260	N	Repetition of field no 6 for more positions
# 7b	261-500	-	Spares
8.	501-512	N	Satellite position_Y- F12.4 (kms)
# 9a	513-740	N	Repetition of field no 8 for more positions
# 9b	741-980	-	Spares
10	981-992	N	Satellite position_Z- F12.4 (kms)
# 11a	993-1220	N	Repetition of field no 10 for more positions
# 11b	1221-1460	-	Spares
12	1461-1472	N	Velocity vector_X- F12.7 (km/sec)
# 13a	1473-1700	N	Repetition of field no – 12
# 13b	1701-1940	-	Spares
14	1941-1952	N	Velocity vector_Y – F12.7 (km/sec)
# 15a	1953-2180	N	Repetition of field no 14
# 15b	2181-2420	-	Spares
16	2421-2432	N	Velocity vector_Z – F12.7 (km/sec)
# 17a	2433-2660	N	Repetition of field no 16
# 17b	2661-2900	-	Spares
# 18a	2901-2912	N	Q1 – F12.7 Q=Quaternion
# 18b	2913-3140	N	Repetition of Q1
# 18c	3141-3152	N	Q2 – F12.7
# 18d	3153-3380	N	Repetition of Q2
# 18e	3381-3392	N	Q3 – F12.7
# 18f	3393-3620	N	Repetition of Q3
# 18g	3621-3632	N	Q4 – F12.7
# 18h	3633-3860	N	Repetition of Q4
# 18i	3861-4012	-	Spares
19	4013-4028	N	Satellite Altitude (meters) – F16.7
20	4029-4054	A	Scene centre time – A 26 (HH:MM:SS:sss)
21	4055-4066	A	Ephemeris/Attitude start time A12 (HH:MM:SS:SSS)
22	4067-4072	N	Time interval for Ephemeris/Attitude values F6.3 in seconds for 1C/1D, in milli seconds for P6

	23	4073-4100		Spares
	24	4101-4110	N	Yaw (deg.) – F10.5
#	25	4111-4300	-	Repetition of field no 24
#	25a	4301-4500		Spares_Yaw
	26	4501-4510	N	Roll (deg.) – F10.5
#	27	4511-4700	-	Repetition of field no 26
#	27a	4701-4900		Spares_Roll
	28	4901-4910	N	Pitch (deg.) – F10.5
#	29	4911-5100	-	Repetition of field no 28
#	29a	5101-5300		Spares_Pitch
	30	5301-5310	N	Scene centre Yaw (deg.) F10.5
	31	5311-5320	N	Scene centre Roll (deg.) F10.5
	32	5321-5330	N	Scene centre Pitch (deg.) F10.5
#	33a	5331-5342	N	Sidereal angle in degrees F12.7
#	33b	5343-5570	-	Repetition of field no 33a
#	33c	5571-6115		Spares
#	33d	6116-6118	N	Star/Earth Sensor RPY Flag 0=Ground Attitude Determination not possible 1=ADAGE determined Q's(ES+GYRO) 2=ADJUST determined Q's(defau)(STAR SEN) 3=AOCE determined Q's
	34	6119-6120	A	Swath Flag (00/01) 01 : Swath Model Done 00 : Swath Model Not Done

Note : Number of Ephemeris/Attitudes values in each record will be as per the field no.5

TABLE 2.4.3.3
EPHEMERIES/ATTITUDE RECORDS
(DEFINITION/CONTENTS) (6120 Bytes)
(For IRS-1C/1D)

FIELD NO	BYTE NUMBER	TYPE	DESCRIPTION
1	1-4	B	Record number of this record within file
2	5-8	B	Record type and subtype octal codes ("366 044 022 022")
3	9-12	B	Length of this record (6120)
4	13-16	N	Record sequence number in Ephemeris and attitude records - I4
5	17-20	N	Number of Ephemeris/Attitude values in this record - I4
6	21-32	N	Satellite position_X- F12.4 (kms)
7.	33-500	-	Repetition of field no 6 for more positions
8.	501-512	N	Satellite position_Y- F12.4 (kms)
9	513-980	-	Repetition of field no 8 for more positions
10	981-992	N	Satellite position_Z- F12.4 (kms)
11	993-1460		Repetition of field no 10 for more positions
12	1461-1472	N	Velocity vector_X- F12.7 (km/sec)
13	1473-1940	-	Repetition of field no – 12
14	1941-1952	N	Velocity vector_Y - F12.7 (km/sec)
15	1953-2420		Repetition of field no 14
16	2421-2432	N	Velocity vector_Z - F12.7 (km/sec)
17	2433-2900	-	Repetition of field no 16
18	2901-4012		Spares
19	4013-4028	N	Satellite Altitude (meters) - F16.7
20	4029-4054	A	Scene centre time - A 26 (HH:MM:SS:sss)
21	4055-4066	A	Ephemeris/Attitude start time A12 (HH:MM:SS:SSS)
22	4067-4072	N	Time interval for Ephemeris/Attitude values F6.3 in seconds for 1C/1D, in milli seconds for P6
23	4073-4100		Spares
24	4101-4110	N	Yaw (deg.) - F10.5
25	4111-4500	-	Repetition of field no 24
26	4501-4510	N	Roll (deg.) - F10.5
27	4511-4900	-	Repetition of field no 26
28	4901-4910	N	Pitch (deg.) - F10.5
29	4911-5300	-	Repetition of field no 28
30	5301-5310	N	Scene centre Yaw (deg.) F10.5
31	5311-5320	N	Scene centre Roll (deg.) F10.5
32	5321-5330	N	Scene centre Pitch (deg.) F10.5
33	5331-6118	-	Spares
34	6119-6120	A	Swath Flag (00/01) 01 : Swath Model Done 00 : Swath Model Not Done

Note : Number of Ephemeris/Attitudes values in each record will be as per the field no.5

TABLE 2.4.3.4

(*) CALIBRATION RECORDS : DEFINITIONS/CONTENTS (6120 Bytes)

FIELD NO.	BYTE NO.	TYPE	DESCRIPTION
1	1-4	B	Record number of this record within file
2	5-8	B	Record type and subtype octal codes ("077 044 022 022")
3	9-12	B	Length of this record (6120)
4	13-16	N	Record Sequence number in calibration record-I4
5	17-20	-	Spares
6	21-24	N	Spectral band number - I4
7	25-28	N	Gain or Dark current/bias flag (bbb1 or bbb2) - I4
8	29-33	N	Number of the detector corresponding to the 1 st value in this record – I5
9	34-36		Spares
10	37-41	N	Number of the detector corresponding to the last value in this record – I5
11	42-44	-	Spares
12	45-48	N	Number of the dead detectors within the 6000 or 4096 or 2100 detectors - I4
13	49-60	-	Spares
14	61-6060	B	Value given is multiplied by 100 (for IRS-P6 otherwise multiplied by 1000 for IRS-1C/1D) 3000 values for gain & bias. (16 bit binary No.is used for gain or bias coded in Integer * 2)
15	6061-6120	-	Spares

(*) Contents applicable for RAW and Radiometrically corrected products.

Gain or bias value (999) will represent the dead detector in the array.

TABLE 2.4.3.5

MAP PROJECTION RECORD - DEFINITION/CONTENTS (6120 Bytes)

FIELD NO.	BYTE NO.	TYPE	DESCRIPTION
1	1-4	B	Record number of this record within file
2	5-8	B	Record type & subtype octal codes ("044 044 022 022")
3	9-12	B	Length of this record (6120)
4	13-16	N	Record sequence number in map projection record I4
5	17-20	-	Spares
6	21-26	A	Map projection identifier - A6
7	27-42	A	Name of reference ellipsoid-A16
8	43-58	N	Semi major axis of geoid (km) - F16.7
9	59-74	N	Eccentricity of the geoid - F16.7
10	75-314	N	Map Projection parameters - 15 F16.7 Ref. APPENDIX-IB
#11	315-320	I6	Total grid points
#12	321-326	I6	Total Grid points in this record
#13	327-332	I6	Scan Line
#14	333-338	I6	Pixel Number
#15	339-354	F16.5	Latitude in degree/ Northing in meter(for UTM)
#16	355-370	F16.5	Longitude in degree/ Easting in meter(for UTM)
#17	371-386	F16.7	Sun Elevation in degree
#18	387-402	F16.7	Sun Azimuth in degrees
#19	403-418	F16.7	Satellite Elevation angle in degree
#20	419-434	F16.7	Satellite Azimuth angle in degree
#21	435-6050	-	Repetition of field no. 13 to 20 for maximum 53 values.
#22	6051-6100	A	Name of reference Datum-A50 (Ref. APPENDIX-1D)
#23	6101-6120		Spares

New Fields in Map Projection Record of LGSOWG for P6

NOTE : Field no. 13 to 20 will be repeated for total grid points in this record (field no. 12 Maxium 53 such values will be accommodated in a single map projection record of 6120 bytes. In case the total grid points(field no 11) exceeds 53. more map projection records will be present

TABLE 2.4.3.6

HISTOGRAM RECORDS DEFINITION/CONTENTS (6120 Bytes)

FIELD NO	BYTE NO	TYPE	DESCRIPTION
1	1-4	B	Record number of this record within file
2	5-8	B	Record type and subtype octal codes ("300 044 022 022")
3	9-12	B	Length of this record (6120)
4	13-16	N	Record sequence number in Histogram - I4
5	17-20	N	Number of Histogram samples in this Record
6	21-24	N	Spectral Band number - I4
7	25-26	N	Sampling rates along pixels - I2
8	27-28	-	Spares
9	29-30	N	Sampling rates along scan lines - I2
10	31-32	-	Spares
11	33-5152	N	Histogram values - I10 For Raw (0-63 1C/1D PAN 0-127 1C/1D/P6 L3 0-127 1C/1D/P6 L4 0-1023 P6 AWiFs) For GEO (0-255 L3,L4,PAN 0-1023 AWiFs)
12	5153-6120	-	Spares

TABLE 2.4.3.7

GCP RECORDS : DEFINITION/CONTENTS (6120 Bytes)

FIELD NO	BYTE NO	TYPE	DESCRIPTION
1	1-4	B	Record number of this record within the file
2	5-8	B	Record type and subtype octal codes ("011 044 022 022")
3	9-12	B	Length of this record (6120)
4	13-16	N	Record sequence number in GCP records (bbb1) - I4
5	17-20	N	Number of GCPs - I4
6	21-6120	-	Spares

TABLE 2.4.3.8**ANNOTATIONS RECORD : DEFINITIONS/CONTENTS (6120 Bytes)**

FIELD NO.	BYTE NO.	TYPE	DESCRIPTION
1	1-4	B	Record number of this record within file
2	5-8	B	Record type and subtype octal codes ("022 333 022 022")
3	9-12	B	Length of this record (6120)
4	13-16	N	Record sequence number in annotation record - I4
5	17-20	N	Number of annotation segments in this record (bbb4) - I4
6	21-52		Spares
			(Segment 1)
7	53-56	N	Segment length - I4
8	57-60	N	Length of the character string - I4
9	61-64	A	Identifier - A4
10	65-100	-	Spares
11	101-180	A	Title for top annotation line 1 - A80
12	181-232	-	Spares
			(Segment 2)
13	233-236	N	Segment length - I4
14	237-240	N	Length of this character string - I4
15	241-244	A	Identifier - A4
16	245-300	-	Spares
17	301-380	A	Title for top annotation line 2- A80
18	381-412	-	Spares
			(Segment 3)
19	413-416	N	Segment length - I4
20	417-420	N	Length of this character string - I4
21	421-424	A	Identifier - A4
22	425-500		Spares
23	501-580	A	Title for top annotation line -3 - A80
24	581-612	-	Spares
			(Segment 4)
25	613-616	N	Segment Length -I4
26	617-620	N	Length of the character string -I4
27	621-624	A	Identifier - A4
28	625-700	-	Spares
29	701-780	A	Title for bottom annotation line -A80
30	781-1700	-	Spares
31	1701-1716	N	Tick mark interval (degree) - F16.7
			Geographic reference marks
32	1717-1720	N	Number of segment "Geographic reference marks" - I4
33	1721-1722	N	Length of geographic character annotation string - I2

34	1723-1724	-	Spares
			Top Geographic reference mark
35	1725-1728	A	Nature of mark - A4 (TOP/BOT/LEFT/RIGHT)
36	1729-1730	N	Number of top marks - I2
37	1731-1736	N	Line Number - I6
38	1737-1742	N	Pixel Number - I6
39	1743-1750	A	Geographic annotation - A8 (e.g. E100: 30)
40	1751-2730	-	Repetition of field No.37, 38 and 39 for no. of top marks
41	2731-2764	-	Spares
			Left Geographic reference mark
42	2765-2768	A	Nature of mark - A4
43	2769-2770	N	Number of left marks - I2
44	2771-3770	-	Repetition of field No. 37,38 and 39 for No. of left marks
45	3771-3783		Spares
			Right Geographic reference mark
46	3784-3787	A	Nature of mark - A4
47	3788-3789	N	Number of right marks - I2
48	3790-4789		Repetition of field No. 37,38 and 39 for No.of Right marks.
49	4790-4800	-	Spares
			Bottom Geographic reference mark
50	4801-4804	A	Nature of mark - A4
51	4805-4806	N	Number of bottom marks - I2
52	4807-5806		Repetition of field No. 37,38 and 39 for No. of Bottom marks
53	5807-6120	-	Spares

TABLE 2.4.3.9

(+) PIXEL & LINE LOOKUP TABLE : DEFINITION/CONTENTS(6120 Bytes)

FIELD NO.	BYTE NO.	TYPE	DESCRIPTION
1.	1-4	B	The record number of this record within the file
2.	5-8	B	Record type and subtype octal codes ("025 333 022 022")
3.	9-12	B	Length of this record (6120)
4.	13-16	N	Record sequence no in line lookup table record I4
5.	17-20		Spares
6.	21-28	N	Tilt angle (deg.) F8.5
7.	29-32	N	No of pixel increment due to panoramic distortion - I4
8.	33-40		Spares
9.	41-46	N	Total scan line increment pointer - I6
10.	47-99	-	Spares
11.	100-101	B	Line lookup table values
12.	102-1099	B	For remaining no of line increment points
13.	1100-1599	-	Spares
14.	1600-1605	N	Total pixel increment pointer – I6
15.	1606-1653	-	Spares
16.	1654-1655	B	Pixel Lookup table values
17.	1656-5653	B	Repetition of field no 16 for remaining no.of pixel increment pointer
18.	5654-6120	-	Spares

(+) Content is applicable for basic stereo product.

Field no 7 to 18 are not valid for IRS-P6.

TABLE 2.4.3.10

ATTITUDE RATE RECORD : DEFINITION/CONTENTS (6120 bytes)

Field No.	Byte No	Type	Definition
1.	1-4	B	Record no of this record in this file
2.	5-8	B	Record Type and sub-type octal codes (“026 044 022 022”)
3.	9-12	B	Length of this record
4.	13-16	N	Record sequence no in this record –I4
5.	17-20	N	Total no of Attitude Rate values in this record.
6.	21-32	A	Attitude rate start time (HH:MM:SS:sss) A12`
7.	33-38	-	Spares
8.	39-44	N	Rate interval (in milliseconds)F6.3
9.	45-54	N	Roll Rate (degree/second)- F10.7
10.	55-64	N	Pitch Rate (degree/second) – F10.7
11.	65-74	N	Yaw Rate (degree/second)- F10.7
12.	75-6044	-	Repetition of field 9, 10, & 11 for more rate values.
13.	6045-6120	-	Spares

Note: Number of Attitude Rate values in each record will be as per the field no.5.

TABLE 2.4.3.11

(*) BOUNDARY RECORD : DEFINITION/CONTENT (6120 Bytes)

FIELD NO.	BYTE NO.	TYPE	DESCRIPTION
1	1-4	B	Record Number of this record in this file
2	5-8	B	Record type and subtype octal codes ("023 333 022 022")
3	9-12	B	Length of this record (6120)
4	13-16	N	Boundary record sequence number – I 4
5	17-20	-	Spares
6	21-24	B	Total no of boundary points
7	25-30	A	Start scan line no. - I 6
8	$31-n \times 2 + 30$	B	Pixel number
9	$n \times 2 + 31 - n \times 2 + 32$	B	Increment flag for the next scan line (-1)
10	$n \times 2 + 33 - 6120$	B	Repetition of field no 8 & 9, for more no of boundary points

(*) n represents the no of pixels on the scan line.

Note: -99 will mark the end of this record.

TABLE 2.4.3.12

BOUNDARY ANNOTATION RECORD : DEFINITION/CONTENTS (6120 bytes)

FIELD NO.	BYTE NO.	TYPE	DESCRIPTION
1	1-4	B	Record Number of this record in this file
2	5-8	B	Record type & subtype octal codes (“024 333 022 022”)
3	9-12	B	Length of this record (6120)
4	13-16	N	Boundary annotations record sequence no. (bbb1) – I4
5	17-20	-	Spares
6	21-24	N	No. of annotations – I4
7	25-32	N	Scan Line no. – I8
8	33-40	N	Pixel no. – I8
9	41-72	A	Character string – A 32
10	73-6120	-	Repetition of field no. 7,8 & 9 for other annotations.

2.4.4 IMAGE DATA FILE

1. File descriptor Record
2. Image data Records

TABLE 2.4.4.1**FILE DESCRIPTOR RECORD : DEFINITIONS/CONTENTS (540 Bytes)**

FIELD NO.	BYTE NO.	TYPE	DESCRIPTION
1	1-180		Refer Table No.2.4.2.1. (Fixed part of the file descriptor record)
			VARIABLE SEGMENT
2	181-186	N	Number of image records – I6
3	187-192	N	Image record length – I6
4	193-216	-	Spares
			PIXEL GROUP DATA
5	217-220	N	Number of bits per pixel (e.g. bbb7) – I4
6	221-224	N	Number of pixels per data group – I4
7	225-228	N	Number of byte per data group (bbb1) – I4
8	229-232	A	Justification and order of pixels within data group (RJLR) –A4
			IMAGE DATA
9	233-236	N	Number of image (Bands) – I4
10	237-244	N	Number of lines per image (Excluding top and bottom border lines) – I8
11	245-248	N	Number of left border pixels per line – I4
12	249-256	N	Number of image pixels per line – I8
13	257-260	N	Number of right border pixels per line – I4
14	261-264	N	Number of top border lines – I4
15	265-268	N	Number of bottom border lines – I4
16	269-272	A	Interleaving indicator – A4
			RECORD DATA IN THIS FILE
17	273-274	N	Number of physical records per line – I2
18	275-276	N	Number of physical records per multi-spectral line – I2
19	277-280	N	Number of bytes of prefix data per record – I4
20	281-288	N	Number of bytes of image data per record – I8
21	289-292	N	Number of bytes of suffix data per record – I4
22	293-296	A	Prefix suffix repeat flag – A4
			PREFIX/SUFFIX DATA LOCATORS
			The following fields are prefix/suffix data locaters. The location is given in 8 bytes as follows: 4 bytes – giving the byte number within the prefix or suffix which begins the field to be located 2 bytes – giving the length in bytes of the field to be located 1 byte - the letter P or S coded in this byte indicates that the information is in the scan line prefix or suffix, respectively 1 byte - a code indicating the type of data in the field coded are (A = Alphanumeric,B = Binary, N = Numeric)

23	297-304	A	Scan line number locator – A8
24	305-312	A	Image (Band) number locator – A8
25	313-320	A	Time of scan line locator – A8
26	321-328	A	Left-fill count locator – A8
27	329-336	A	Right-fill count locator – A8
28	337-440	-	Spares
29	441-448	N	Maximum data range of pixels (starting from `0' to 255/127/63) – I8
30	449-540	-	Spares

TABLE 2.4.4.2

IMAGE DATA RECORDS : DEFINITION/CONTENTS

FIELD NO.	BYTE NO.	TYPE	DESCRIPTION
1	1-4	B	Record sequence number of this record within the file
2	5-8	B	Record type and subtype octal codes (“355 355 022 022”)
3	9-12	B	Length of this record
4	13-16	B	Scanline Number
5	17-18		Spares
6	19-20	B	Band number
7	21-32	-	Spares
8	$33-(32+np)=X$	B	Image data
9	$(X+1) - (X+18)$	-	Spares
10	$(X+19) \text{ to totB}$	-	Spares

Note :

np => Field no. 12 variable segment of file descriptor record.

TotB => Field no. 3 of variable segment of file descriptor record.

2.4.5 TRAILER FILE

100. Trailer file descriptor Record

2. Trailer Records

TABLE 2.4.5.1

TRAILER FILE DESCRIPTOR : DEFINITION/CONTENTS (360 bytes)

FIELD NO	BYTE NO	TYPE	DESCRIPTION
1	1-180	-	see table no 2.4.2.1 (fixed part of the file descriptor record)
2	181-184	N	Number of trailer records in the file – (I4)
3	185-188	N	Length in bytes of the trailer records (b 360) – I4
4	189-360	-	Spares

TABLE 2.4.5.2

TRAILER RECORD : DEFINITION/CONTENTS (360 Bytes)

FIELD NO.	BYTE NO.	TYPE	DESCRIPTION
1	1-4	B	Record number of this record within the file
2	5-8	B	Record type and subtype octal codes (“022 366 022 022”)
3	9-12	B	Length of this record (360 Bytes)
4	13-16	N	Record sequence number in trailer records (bbbN) – I4
5	17-20	-	Spares
6	21-35	N	Cloud cover values giving percent cloud cover in different parts of the picture 3 bytes/value) – 5I3
7	36-95		Spares
8	96-99	N	No. of parity errors for corresponding band no. – I4
9	100-103	N	No. of remaining lines loses in the scene for corresponding band no. – I4
10	104-107	N	Line losses mir
11	108-360	-	Spares

2.4.6 NULL FILE

1. Null volume descriptor record.

TABLE 2.4.6.1**NULL VOLUME DESCRIPTOR RECORD : DEFINITIONS/CONTENTS**
(360 BYTES)

FIELD NO.	BYTE NO.	TYPE	DESCRIPTION
1	1-4	B	Record sequence number in this file (1)
2	5-8	B	Record type and subtype octal codes ("022 300 077 022")
3	9-12	B	Length of this record (360 bytes)
4	13-14	A	ASCII/EBCDIC flag - (Ab)
5	15-16	-	Spares
6	17-28	A	Super structure control document number-A12
7	29-30	N	Control document revision number - I2
8	31-32	A	Control document revision letter - A2
9	33-44	A	Software release number -, A12
10	45-60	A	Physical tape ID - A16
11	61-76	A	Logical volume ID - A16
12	77-92	A	Logical volume set ID - A16
13	93-94	N	Number of physical volume in the set - I2
14	95-96	N	Physical volume number : Start of logical volume - I2
15	97-98	N	Physical volume number : End of logical volume - I2
16	99-100	N	Physical volume no. containing this descriptor - I2
17	101-104	N	First file no. referenced in this physical volume - I4
18	105-108	N	Logical volume No. within volume set - I4
19	109-112	N	Logical volume No. within physical Volume - I4
20	113-360	-	Spares

RECORD TYPE AND SUBTYPE CODES FOR LGSOWG
IRS DATA PRODUCTS

RECORDS	BYTE 5 (Octal)	BYTE 6 (Octal)	BYTE 7 (Octal)	BYTE 8 (Octal)
Volume Descriptor	300	300	022	022
File Pointer	333	300	022	022
Text	022	077	022	022
File Descriptor	077	300	022	022
Header	022	022	022	022
Ephemeris/Attitude	366	044	022	022
Calibration	077	044	022	022
Histogram	300	044	022	022
Map projection	044	044	022	022
GCPs	011	044	022	022
Annotation	022	333	022	022
Boundary	023	333	022	022
Boundary Annotation	024	333	022	022
Lookup table	025	333	022	022
Attitude Rate	026	044	022	022
Image Data	355	355	022	022
Trailer	022	366	022	022
Null Volume Descriptor	022	300	077	022

FIGURE – 1: LAYOUT OF SUPER STRUCTURE FORMAT IN DAT

FILE NUMBER	CONTENTS	FILE NAME
File 0	: Volume Descriptor : File Pointer (1) : File Pointer (2) : File Pointer (3) : Text EOF (x)	Volume Directory
File 1	: Leader file Descriptor : Header Record : Ancillary Record : Annotation Record : Boundary Record EOF (x)	Leader file
File 2	: Imagery file descriptor : Image data records EOF (x)	Imagery file
File 3	: Trailer file Descriptor : Trailer records EOF (x)	Trailer file
File NULL	: NULL Volume Descriptor Directory file EOF EOF EOF	Null Volume Directory file

(x) EOF = End of file tape mark

LIST OF ACRONYMS TO BE USED

SATELLITE	SENSOR
1C IRS-1C	3 LISS-III A PAN-A B PAN-B C PAN-C D PAN-D M MIR W WIFS
1D IRS-1D	LISS-IV
P6 IRS-P6	3 LISS-III M LISS-IV (MONO) MX LISS-IV (MX) W AWiFS

SUBSCENES

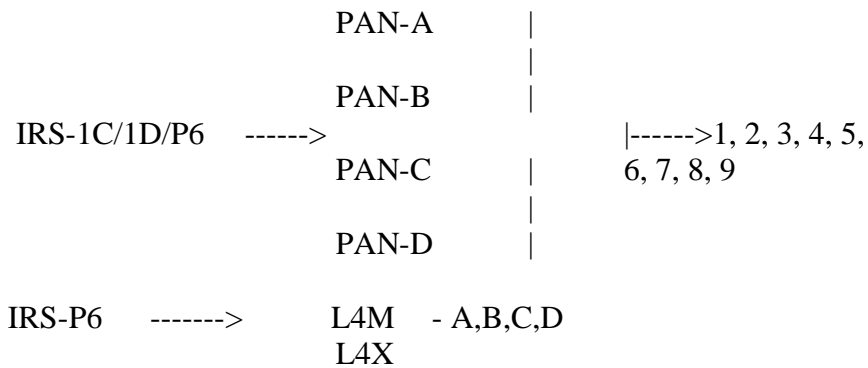

PROJECTION

O NO PROJECTION
P POLYCONIC
S SOM
U UTM (Ref. ellip-Int)
V UTM (Ref. ellip-Clarke)
R STEREOSCOPIC
L LAMBERTS' conformal
conical proj

RESAMPLING

O NO SAMPLING
B BILINEAR
C CC
D DS 16
N NN
K KAISER

PROC LEVEL

3 PRECISION
2 BULK
1 RAD
0 RAW

ENHANCEMENTS

00 NO ENHANCEMENTS
01 CORRECTED
02 HIST EQ

DATA FORMAT

6 BIL
7 BSQ
B Fast Format Rev. C
T GeoTIFF (Grey Scale)
R GeoTIFF (RGB)
H HDF

APPENDIX – 1A: CLARIFICATION OF EXISTING FORMAT

Volume Directory File

- *Volume Descriptor Record:*
In Field No 10 the Symbol U = C/T/D represents
C : For Compact Disk (CD).
D : For DATs (both 4mm & 8mm) of different Capacity.
U : For Other Output Media.
Z: DISK

Leader File

- *Calibration Record:*
This record is valid only for RAW products only.
- *GCP Record:*
This record is not valid for geometrically uncorrected (RAW & RAD) products. This is a dummy record.
- *Annotations Record:*
Annotation titles from field no 5 to field no. 30 are relevant for photo products only.
- *Boundary Annotation Record:*
This record is currently not applicable for IRS products. So now dummy record has been put.
- *Pixel & Line Lookup table Record:*
Valid for Basic stereo products, for other products one dummy record will be there.
- *Attitude Rate Record:*
It is relevant for geometrically uncorrected (RAW & RAD) products. (for IRS-1C/1D only). For IRS-P6 this is a dummy record.
 - Field No. 6 Byte No 21-32 Attitude rate start time is in HH:MM:SS: mmm, A12 format.
- *Boundary Record:*
This record is currently not applicable for IRS products. So now dummy record has been put.

NOTE:

1. All time information except product creation time is given in UT. Scene covered by Indian region will have IST for scene at field no.20 of Ephemeris/attitude record of Leader file.

2. Conversion formula for Digital Count to radiance is as follows.

$$\text{Lrad} = (\text{DN}/\text{MaxGray}) * (\text{Lmax} - \text{Lmin}) + \text{Lmin}$$

Where

Lrad :Radiance for a given DN value.

DN :Digital Count

MaxGray:IRS-1C/1D : 63 for PAN & 127 for WiFS & LISS-3 for Raw Products only.
255 for Corrected products.

IRS-P6 : 127 for LISS-4 and LISS-3 and 1023 for AWiFS.

Lmin/Lmax :minimum/Maximum radiance value for a given bias.

APPENDIX – 1B: USGS Projection Parameters

Fast Format Revision C Supports 17 USGS projections. For all projections except State Plane, USGS parameters 1 and 2 are semi major and minor axes of the requested earth ellipsoid. This has been adapted for Super Structure (LGSOWG) format.

- * Not every parameter will be used by the designated projection.
- * If a parameter is not used the field for the parameter will be initialized to Zero.
- * All latitude and longitude fields will be specified Decimal Degree (floating point)
- * All other fields will be specified as double precision floating point values.

Please note that all co-ordinates for State Plane System contained in the Fast Format is in map metres (not in feet).

C1(U) Universal Transverse Mercator (UTM)

Parameter 3* UTM Zone number (Optional)

C2(A) Albers Conical Equal Area (ACEA)

Parameter 3	Latitude of first Standard Parallel
Parameter 4	Latitude of second Standard Parallel
Parameter 5	Longitude of central meridian
Parameter 6	Latitude of projection's Origin
Parameter 7	False Easting (in metres)
Parameter 8	False Northing (in metres)

C3(L) Lamberts Conformal Conic (LCC)

Parameter 3	Latitude of first Standard Parallel
Parameter 4	Latitude of second Standard Parallel
Parameter 5	Longitude of central meridian
Parameter 6	Latitude of projection's Origin
Parameter 7	False Easting (in metres)
Parameter 8	False Northing (in metres)

C4(M) Mercator (Mer)

Parameter 5	Longitude of central meridian
Parameter 7	False Easting (in metres)
Parameter 8	False Northing (in metres)

C5(D) Polar Stereographic (PS)

Parameter 5	Longitude directed straight down below pole of map
Parameter 6	Latitude of true scale
Parameter 7	False Easting (in metres)
Parameter 8	False Northing (in metres)

C6(P) Polyconic (POL)

Parameter 5	Longitude of central meridian
Parameter 6	Latitude of projection's Origin
Parameter 7	False Easting (in metres)
Parameter 8	False Northing (in metres)

C7(T) Tranverse Mercator (TM)

Parameter 3	Scale Factor at central meridian
Parameter 5	Longitude of central meridian
Parameter 6	Latitude of projections's origin
Parameter 7	False Easting (in metres)
Parameter 8	False Northing (in metres)

C8(H) Stereographic (SG)

Parameter 5	Longitude of central meridian
Parameter 6	Latitude of centre of projection
Parameter 7	False Easting (in metres)
Parameter 8	False Northing (in metres)

C9(Z) Lamberts Azimuthal Equal Area (LAEA)

Parameter 5	Longitude of central meridian
Parameter 6	Latitude of centre of projection
Parameter 7	False Easting (in metres)
Parameter 8	False Northing (in metres)

C10(E) Azimuthal Equidistant (AE)

Parameter 5	Longitude of central meridian
Parameter 6	Latitude of centre of projection
Parameter 7	False Easting (in metres)
Parameter 8	False Northing (in metres)

C11(G) Gnomonic (GNO)

Parameter 5	Longitude of central meridian
Parameter 6	Latitude of centre of projection
Parameter 7	False Easting (in metres)
Parameter 8	False Northing (in metres)

C12(R) Orthographic (OG)

Parameter 5	Longitude of central meridian
Parameter 6	Latitude of centre of projection
Parameter 7	False Easting (in metres)
Parameter 8	False Northing (in metres)

C13(N) General Vertical Near-Side Perspective (GVNP)

Parameter 3	Height of perspective point above sphere
Parameter 5	Longitude of centre of projection
Parameter 6	Latitude of centre of projection
Parameter 7	False Easting (in metres)
Parameter 8	False Northing (in metres)

C14(I) Sinusoidal (SIN)

Parameter 5	Longitude of central meridian
Parameter 7	False Easting (in metres)
Parameter 8	False Northing (in metres)

C15(C) Miller Cylindrical (MC)

Parameter 5	Longitude of central meridian
Parameter 7	False Easting (in metres)
Parameter 8	False Northing (in metres)

C16(V) Van Der Grinten (VDG)

Parameter 5	Longitude of central meridian
Parameter 7	False Easting (in metres)
Parameter 8	False Northing (in metres)

C17(S) Space Oblique Mercator (SOM)

Parameter 4	Angle of azimuth east of north for central line of projection
Parameter 9	Longitude of the ascending Node
Parameter 11	Longitude of descending Node

C18(K) Tranverse Mercator (Gauss-Krueger)(TM)

Parameter 3	Scale Factor at central meridian
Parameter 5	Longitude of central meridian
Parameter 6	Latitude of projections's origin
Parameter 7	False Easting (in metres)
Parameter 8	False Northing (in metres)

APPENDIX - 1C : Earth Ellipsoids

This appendix contains the earth ellipsoids used in products.

Ellipsoid Name	Semi-Major Axis (meters)	Semi-Minor Axis (meters)	Mnemonics
Clarke 1866	6378206.400000	6356583.800000	CLARKE_1866
Clarke 1880	6378249.145000	6356514.869550	CLARKE_1880
International 1967	63778157.500000	6356772.200000	INTERNATL_1967
International 1909	6378388.000000	6356911.646130	INTERNATL_1909
WGS 66	6378145.000000	6356759.769356	WGS_66
WGS 72	6378135.000000	6356750.519915	WGS_72
WGS 84	6378137.000000	6356752.314200	WGS_84
GRS 1980	6378137.000000	6356752.314140	GRS_80
Airy	6377563.396000	6356256.910000	AIRY
Modified Airy	6377340.189000	6356034.448000	MODIFIED_AIRY
Everest	6377276.345200	6356075.41330	EVEREST
Modified Everest	6377304.063000	6356103.039000	MODIFIED_EVEREST
Mercury 1960	6378166.000000	6356784.283666	MERCURY_1960
Modified Mercury 1968	6378150.000000	6356768.337303	MOD_MERC_1968
Bessel	6377397.155000	6356078.962840	BESSEL
Walbeck	6376896.000000	6355834.846700	WALBECK
Southeast Asia	6378155.000000	6356773.320500	SOUTHEAST_ASIA
Australian Natl.	6378160.000000	6356774.719000	AUSTRALIAN_NATL
Krassovsky	6378245.000000	6356863.018800	KRASOVSKY
Hough	6378270.000000	6356794.343479	HOUGH
6370997 Sphere	6370997.000000	6370997.000000	6370997_M_SPHERE

APPENDIX - 1D : Ellipsoid and Datum Mnemonics

Ellipsoid Name	Ellipsoid Mnemonic	Possible Datum Name	Datum Mnemonics
Clarke 1866	CLARKE_1866	Datum_North_American_Datum_1927	NAS-E
Clarke 1880	CLARKE_1880	Datum_Adindan	ADI-M
International 1967	INTERNATL_1967	Datum_New_Zealand_Geodetic_Datum_1949	GEO
International 1909/1924	INTERNATL_1909	Datum_European_Datum_1950	EUR-M
WGS 66	WGS_66	WGS_66	WGS_66
WGS 72	WGS_72	WGS_72	WGS_72
WGS 84	WGS_84	WGS_84	WGS_84
GRS 1980	GRS_80	Datum_North_American_Datum_1983	NAR-B
Airy	AIRY	Datum_OSGB_1936	OGB_M
Modified Airy	MODIFIED_AIRY	Datum_TM65	IRL
Everest	EVEREST	Datum_Kalianpur	IND-I
Modified Everest	MODIFIED_EVEREST	Datum_Kalianpur	IND-I
Mercury 1960	MERCURY_1960	NOT DEFINED	
Modified Mercury 1968	MOD_MERC_1968	NOT DEFINED	
Bessel	BESSEL	Datum_Tokyo	TOY-M
Walbeck	WALBECK	Datum_European_Datum_1950	EUR-M
Southeast Asia	SOUTHEAST_ASIA	Datum_Southasia	SOA
Australian Natl.	AUSTRALIAN_NATL	Datum_Australian_Geodetic_datum_1984	AUG
Krassovsky	KRASSOVSKY	Datum_Pulkovo_1942	PUK
Hough	HOUGH	Datum_Wake-Eniwetok_1960	ENW
6370997 Sphere	6370997_M_SPHERE	NOT DEFINED	

APPENDIX - II: Super Structure format Layout

APPENDIX –II

Super Structure Format Layout (BSQ)

Volume Directory

File Desc. Rec

Leader File

File Desc. Rec

Image Data File B1

File Desc. Rec

Image Data File B2

File Desc. Rec

Image Data File B3

File Desc. Rec

Image Data File B4

File Desc. Rec

Trailer Record

Null Volume Directory

< EOF >
< EOF >
< EOF >

**Super Structure Format
Layout (BIL)**

Volume Directory

File Desc. Record
Leader File

File Desc. Record
Image Data File
B1
B2
B3
B4

.
. .
. . .

File Desc. Record
Trailer File

Null Volume Dir.

< EOF >
< EOF >
< EOF >

SUPER STRUCTURE FORMAT LAYOUT

ONE LOGICAL VOLUME (More than one physical volume) – BIL

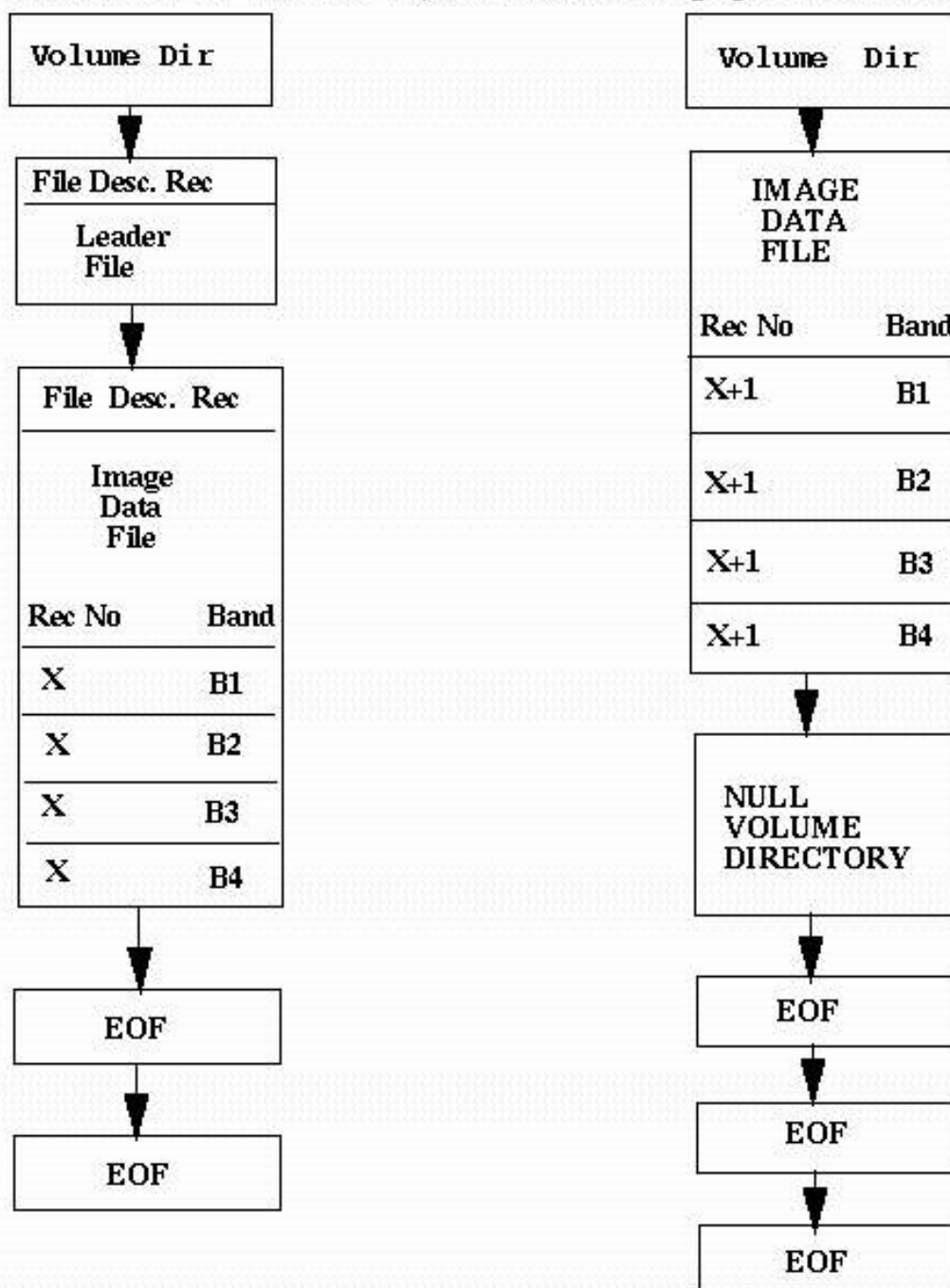

TWO LOGICAL VOLUME (More than one physical volume)

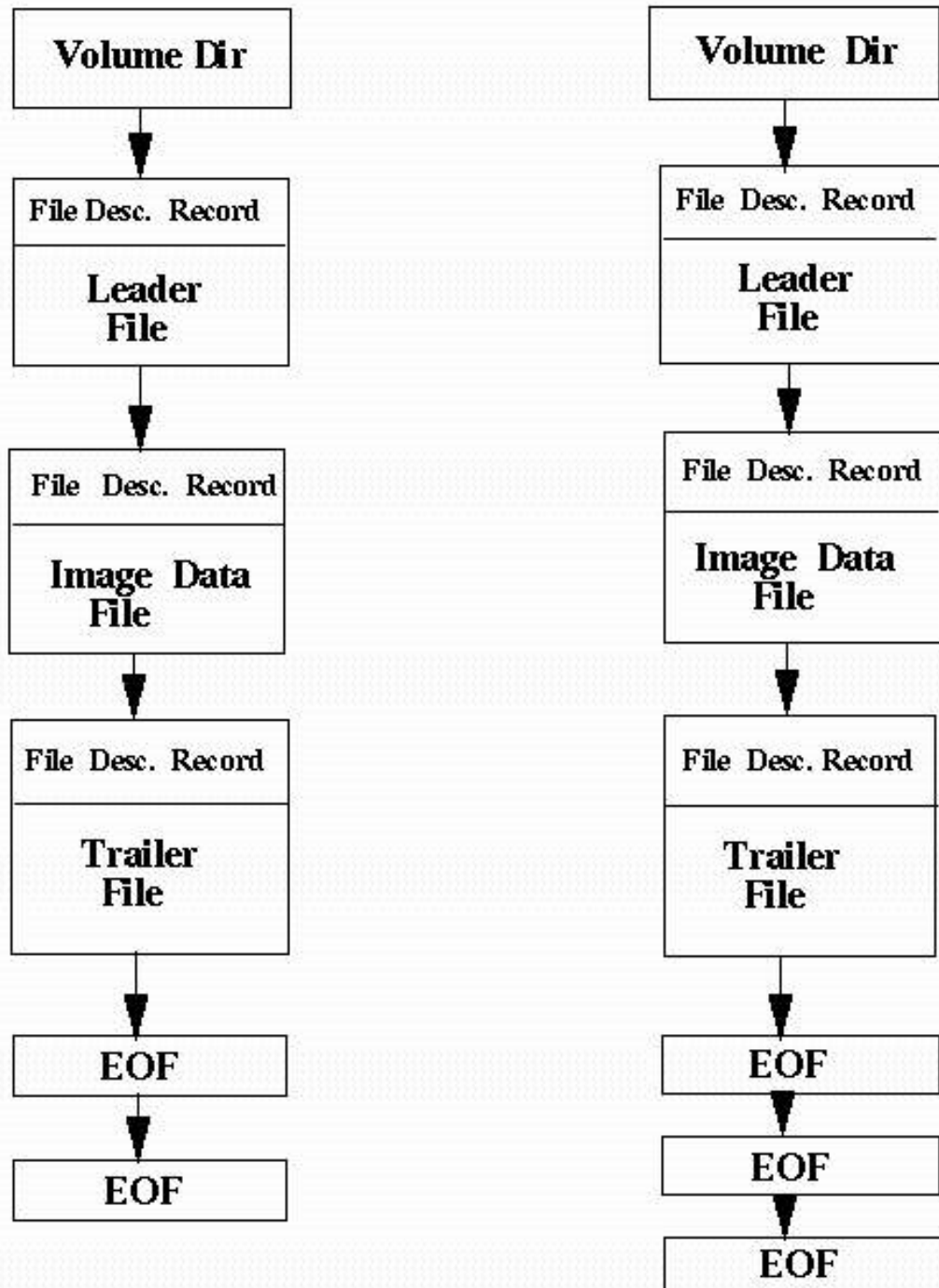

TWO LOGICAL VOLUME (ONE PHYSICAL VOLUME)

Volume Directory

File Desc. Record
Leader File

File Desc. Record
Image Data File

File Desc. Record
Trailer File

Volume Directory

File Desc. Record
Leader File

File Desc. Record
Image Data File

File Desc. Record
Trailer File

Null Volume Dir.

< EOF >
< EOF >
< EOF >